

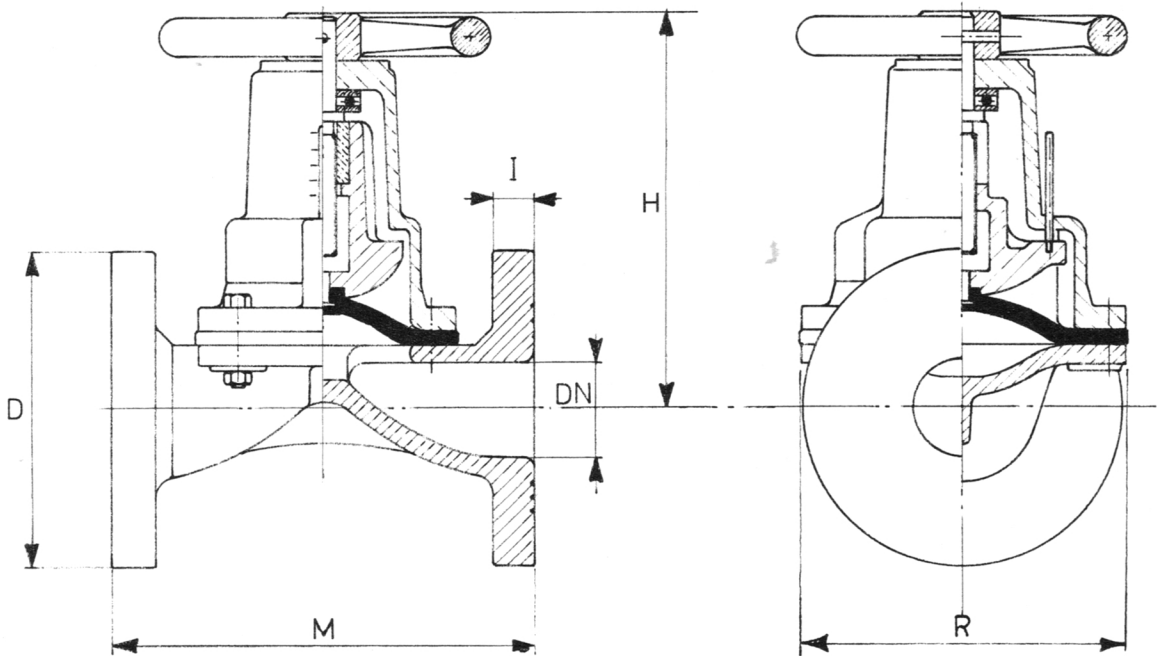

VALVOLE SIRSI - TIPO "FLAV-DIN" A MEMBRANA
 TYPE "FLAV-DIN" SIRSI DIAPHRAGM VALVES
 VANNES SIRSI A MEMBRANE - TYPE "FLAV-DIN"

TN 2028/A



CARATTERISTICHE E DIMENSIONI - SPECIFICATIONS AND DIMENSIONS - CARACTERISTIQUES ET DIMENSIONS

DN	D	H	I	M	R	Press. max. Bar	Pesi Weights - Poids Kg.	NOTE
15	95	80	14	130	70	10	2,300	
20	105	80	16	150	70	10	2,500	
25	115	135	16	160	100	8	5,400	
32	140	140	18	180	130	8	7,000	
40	150	175	18	200	145	7	11,000	
50	165	185	20	230	170	7	13,500	
65	185	200	20	290	180	7	17,000	
80	200	225	22	310	210	7	26,000	
100	220	285	22	350	235	6	35,500	
125	250	390	24	400	270	4	60,000	
150	285	400	24	480	330	4	70,000	
200	340	550	28	600	420	3	143,000	
250	395	670	32	730	480	3	230,000	
300	445	700	32	850	580	3	330,000	
350	505	700	32	980	580	3	345,000	

Dimensioni flange: secondo norme UNI 2223 - PN 10-16 o norme DIN 2532 - ND 10. A richiesta secondo norme ANSI 125 o 150, norme B.S. o altre norme.

Scartamento: secondo norme DIN 3202 F1.

Corpo: in ghisa o acciaio al C. con o senza rivestimento di ebanite, gomma, hypalon. In acciaio inossidabile tipo AISI 304-316.

Membrana: in elastomeri sintetici o in PTFE.

Flange dimensions: to DIN 2532 - ND 10 or UNI 2223 - PN 10-16 standards. Optionally to ANSI 125 or 150, to B.S. or other standards.

Length over flanges: to DIN 3202 F1 standards.

Valve body: cast iron, or carbon steel with or without hard rubber - soft rubber - hypalon - lining. Stainless steel type AISI 304-316.

Diaphragm: synthetic elastomers or PTFE.

Dimensions des brides: suivant les normes DIN 2532 - ND 10 ou UNI 2223 - PN 10-16. Sur demande, suivant les normes ANSI 125 ou 150, les normes B.S. ou autres normes.

Encombrement: suivant normes DIN 3202 F1.

Corps de la vanne: en fonte ou acier au C. avec ou sans revêtement d'ébonite, caoutchouc, hypalon. En acier inoxydable type AISI 304-316.

Membrane: en élastomères synthétiques ou en PTFE.