

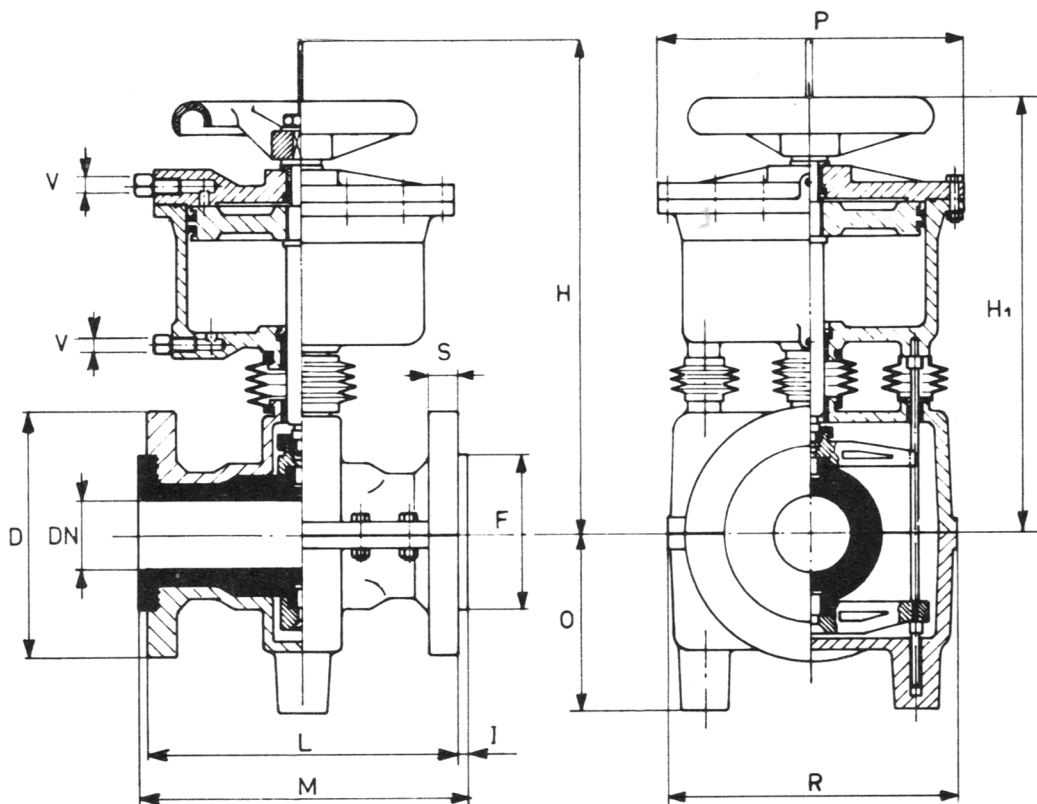

VALVOLE SIRSI - TIPO "PACV" PRESSIONE
 APRE-CHIUDE CON VOLANTINO DI EMERGENZA
 TYPE "PACV" PRESSURE OPENING-CLOSING
 SIRSI VALVES WITH EMERGENCY HANDWHEEL
 VANNES SIRSI - TYPE "POFV" PRESSION
 OUVRE-FERME AVEC VOLANT DE SECOURS

TN 2023/D



CARATTERISTICHE E DIMENSIONI - SPECIFICATIONS AND DIMENSIONS - CARACTERISTIQUES ET DIMENSIONS

DN	D	F	H	H ₁	I	L	M	O	P	R	S	V	Press. max. Bar	Pesi Weights - Poids Kg.	NOTE
10/12	90	44	270	235	2	130	135	25	150	76	14	1/4" G	8	3,000	
15	95	44	270	235	2	130	135	28	150	80	14	1/4" G	8	3,500	
20	105	44	270	235	5	150	160	28	150	80	16	1/4" G	5	4,100	
25	115	60	290	255	5	160	170	40	150	115	16	1/4" G	5	5,000	
32	140	60	290	255	5	180	190	40	150	115	18	1/4" G	5	5,500	
40	150	78	390	310	5	200	210	50	200	135	18	1/4" G	4	7,300	
50	165	108	400	320	5	230	240	55	200	165	20	1/4" G	4	11,000	
65	185	123	425	335	7	290	305	60	200	185	20	1/4" G	3,5	13,500	
80	200	140	590	460	10	310	330	180	285	250	22	1/4" G	3,5	26,000	
100	220	160	600	460	10	350	370	205	285	300	22	1/4" G	3,5	32,500	
125	250	210	840	650	10	400	420	210	375	330	24	1/4" G	2,5	65,100	
150	285	240	855	665	10	480	500	245	375	400	24	1/4" G	2	75,100	
200	340	295	1050	800	10	600	620	320	450	460	28	1/4" G	2	106,500	

Apertura e chiusura mediante immissione di aria compressa nel cilindro pneumatico. Dotata di volantino per la manovra manuale di emergenza.

Cilindro e pistone: in lega di alluminio.

Corpo: normalmente in alluminio.

Caratteristiche costruttive: come per i tipi "SD" (TN 2014) e "SC" (TN 2015).

Delivery of compressed air to the pneumatic cylinder opens and closes the valve. With handwheel for emergency manual operation.

Cylinder and piston: aluminum alloy.

Valve body: normally aluminum.

Construction features: as per types "SD" (TN 2014) and "SC" (TN 2015).

Ouverture et fermeture de la vanne par admission d'air comprimé dans le cylindre pneumatique. Avec volant de secours pour la manoeuvre manuelle.

Cylindre et piston: en alliage en aluminium.

Corps de la vanne: normalement en aluminium.

Caractéristiques constructives: comme pour les types "SD" (TN 2014) et "SC" (TN 2015).